

VoCALL

Fire Telephone & Disabled Refuge System



Installation & Commissioning Instructions

Software Version 4.x

**Please Read Carefully Before
Commencing Any Installation Works**



Introduction

An EVCS is a fixed, secure, bi-directional, full duplex voice communication system to assist fire fighters in an emergency in high rise buildings or large sites where Radio communication may not work, and covers the operation of both fire telephones and disabled refuge systems.

The VoCALL Emergency Voice Communications System (EVCS) is designed to fully comply with BS5839-Part 9:2003 (abb. Pt9) for use as a Fire Telephone system, Disabled Refuge Call system or as a combined system when both Fire Telephones and Disabled Refuge Points are required.

Suitability

Fire telephone systems are recommended for all public buildings and multi story buildings over four floors by BS9999.

Disabled Refuge systems are required in buildings where the public or disabled staff gain access to any floor other than the ground floor using lifts or other aids, or where ground floor emergency exits lead to stairs.

Product Overview

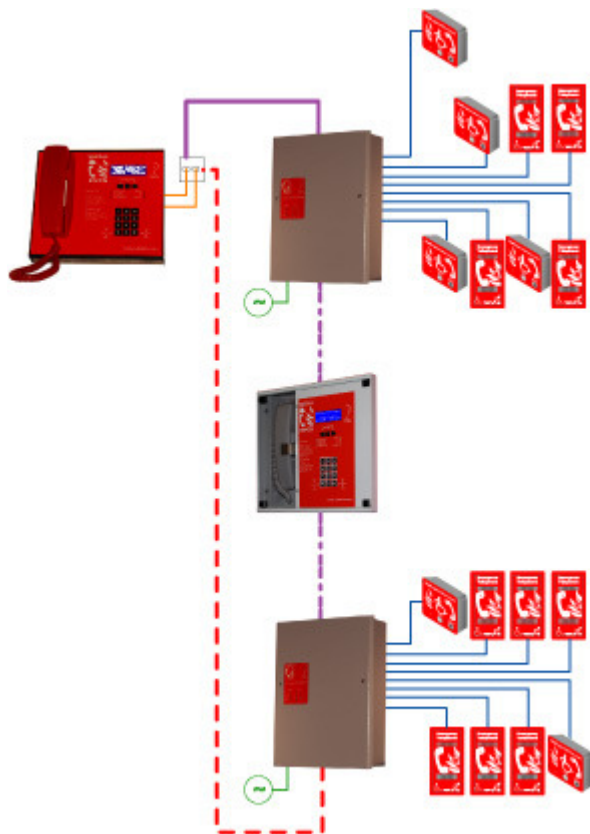

provides an ELV maintained supply to the control handsets.

A VoCALL EVCS comprises of three functional blocks, the master handset (VCM) the eight line Exchanges (VCX-8) and outstations, (type A, type B or Jack points), with the quantities of these basic units being adjusted to suit the application.

The VoCALL EVCS has been designed on a star and ring network topology; in the most cases this will reduce the cable requirements from all ring-based systems and star systems. The topology consists of a ring formed from either 2 off four core 1mm CSA cables (soft skin up to 500m per leg, MICC 200m per leg) or 1 four pair 0.5mm CSA fire rated data cable. The exchange units and the control handsets sit on this ring and communicate using a high speed balanced RS422 network, a bi-directional audio pair and a power pair, which

Indications and Controls

The faults on a VoCALL EVCS system are displayed in two locations, on the exchange with the fault, and at the VCM master handset(s).

Master Handset Indication.

The master handset has the following indications:-

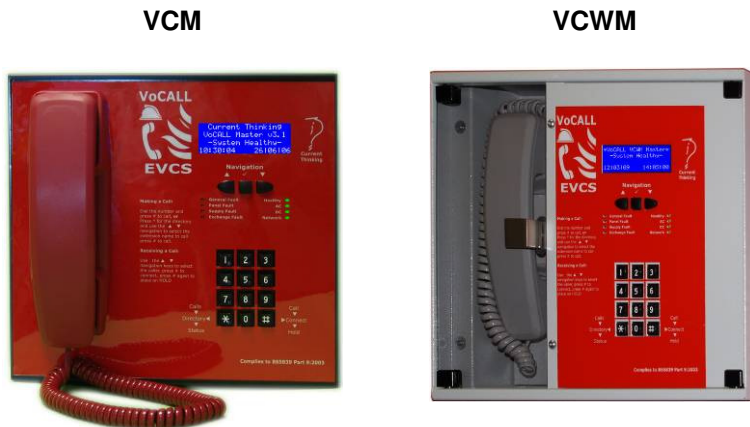

Health Indicators (Green)

- | | |
|---------|---|
| Healthy | The system is ready for use and fault free. |
| AC | Indicates healthy AC mains available. |
| DC | Indicates the battery supply is available. |
| Network | The communication network is operating. |

Fault Indicators (Yellow)

- | | |
|----------------|--|
| General Fault | A fault exists on the system. |
| Panel Fault | The processor, main phone or watchdog timer have tripped, engineer assistance is required. |
| Supply Fault | Either the AC supply or DC supply is unavailable, or a fuse has ruptured. |
| Exchange Fault | A fault exists on one of the remote exchanges or an exchange is missing from the system. |

Fault Log

The Fault log can be accessed on the master handset by entering the PIN; this should only be done by an engineer.

Exchange Indications

The master handset has the following indications:-



LED	Meaning
Fault	This is a common fault LED and indicates that a current fault exists on this exchange unit, this can be a line fault, processor failure, power supply fault or network connection fault.
Supply	There is a fault with the power supply section of the exchange unit, this could be lack of either AC or DC, rupture of a fuse or failure of the VRSLA cell to hold charge
AC Ok	The mains AC voltage is present
DC Ok	The backup battery supply and charger are available to operate the exchange in the event of a mains failure

Line LEDs

All 8-line indicators are identical in operation, and represent the exchange lines (numbered 1 to 8 on the exchange polycarbonate decal).

Each LED can have 3 states to indicate a fault as follows:-

LED State

Off	The line is healthy or has not been initialised so fault reporting is disabled
On Steady	The line is short circuit or has an earth fault
Flashing	The line is open circuit

A Fault LED on an exchange will illuminate the Exchange Fault LED on the master handsets, and place a date time stamped entry into the master handset fault log.

Important Safety Information

This Equipment must only be installed and maintained by suitably skilled and competent person.

This Equipment is defined as Class 1 in EN60950 (Low Voltage Directive) and must be EARTHED.



Caution



INDOOR USE ONLY



WARNING

SHOCK HAZARD-

ISOLATE BEFORE OPENING

WARNING

TO REDUCE THE RISK OF FIRE OR ELECTRIC

SHOCK, DO NOT EXPOSE THIS UNIT TO RAIN OR
MOISTURE

WARNING

THIS UNIT MUST BE EARTHED

WARNING

NO USER SERVICABLE PARTS

Each exchange unit requires a 3A spur, returning to a breaker clearly marked **Fire Telephone DO NOT TURN OFF**. If the units are distributed around a site it is essential all units are on the same mains phase, as they are classified TEN 230V, powering from different phases can mean a 440V potential can be present in a unit during a major fault incident.



Anti-static handling guidelines

Make sure that electro-static handling precautions are taken immediately before handling PCBs and other static sensitive components

Before handling any static-sensitive items, operators should get rid of any electrostatic charge by touching a sound safety earth, such as a radiator. Always handle PCBs by their sides and avoid touching any components. PCBs should be stored in a clean, dry place that is free from vibration, dust and excessive heat.

Storing the PCBs in a suitable cardboard box will also guard them against mechanical damage.

Unpacking the Exchange Unit

Remove the exchange from its packing, and using the HEX key supplied remove the front cover, being careful to remove the earth lead.

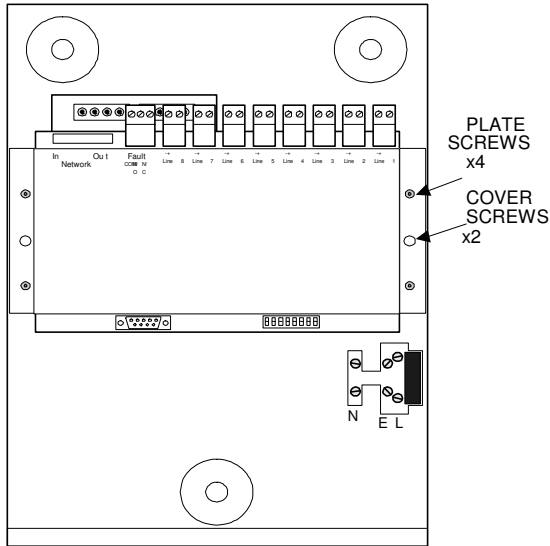

Remove the front panel plate containing the circuit boards, this has a connection to the mains transformer, which needs to be removed, Exercise static precautions to prevent damage to the electronics, store the front panel assembly safely until the exchange is mounted and cables have been attached.

Do not remove knockouts while the circuit board is still fitted.

Preparation

Remove knockouts & cut gland holes. Decide how the wiring will be brought into the panel and remove the required knockouts for cable entry. If a knockout is removed fill the hole with a good quality cable gland. 12 knockouts are provided, 11 on the top face from left to right, Network In, Network Out, Fault, and Line 8 thru line 1. On the bottom face a single knockout is for the incoming mains. If additional holes are required, then the can be drilled as shown below, taking care not to obscure the battery or PCB locations. Unused knockouts must be left unopened to comply with the LVD, accidentally knocked out holes should be blanked off. This work must be carried out prior to the re-installation of circuit boards.

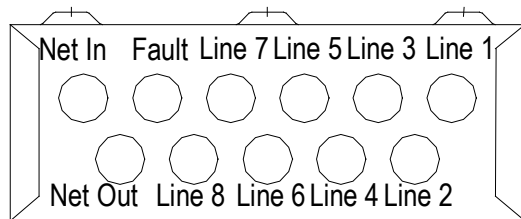
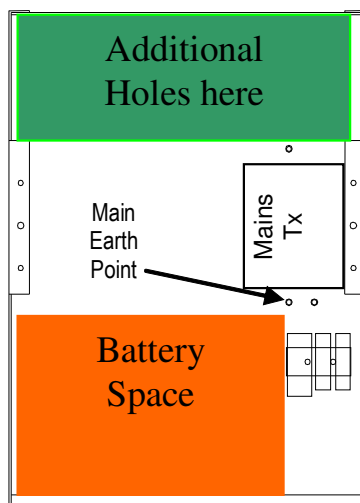

Connection Details



Do not test wiring with an insulation tester (Megger) with any equipment connected, as the 500 Volt test voltage will destroy these devices totally.

You must observe local wiring regulations. Do not run SELV and LV cables in the same enclosure without adequate insulation between them.

Handsets:

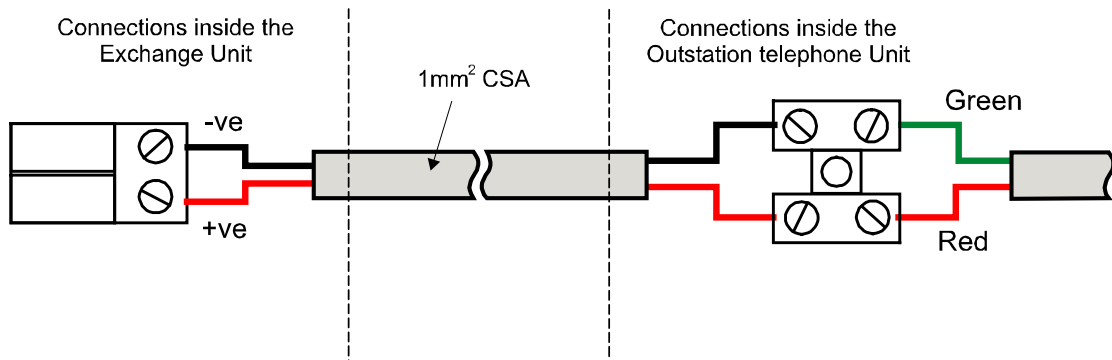

Line + connector on exchange to Red Phone lead

Line – connection on exchange to Green Phone Lead

Network:

The network links either an exchange to an exchange or a master controller to an exchange.

Each unit on the system has a net in and net out. The network connects from the net out of the one unit to the net in on another-all eight core must be connected from the net out to the net in as follows:

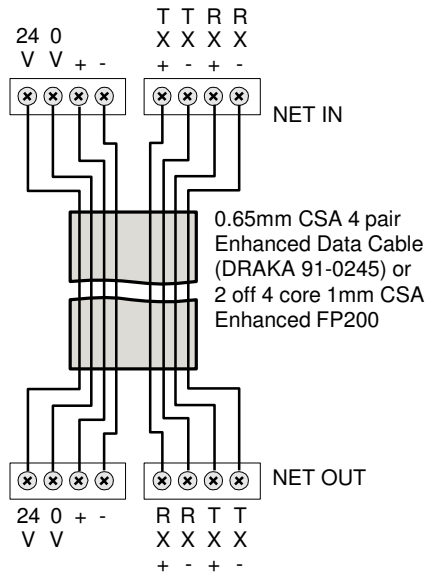

This cable must be FP200 draka 91-0245 or similar soft skin enhanced type cable and should be a maximum of 1mm CSA

The net out connection from the last exchange unit or master handset on a multi exchange system can be brought back to the net in on the first exchange or master handset to form a redundant ring system, so that if the network connection is broken, then no loss of system functionality.

2ND Fix

Replace the front panel PCB plate by attaching the transformer lead and fixing with the four Philips screws.

Attach all plugs ensuring they fit squarely into the connectors.

VoCALL exchange unit switch settings

Each exchange unit has a unique network address. This address is set by the dip switches on the exchange unit. The address is a binary number given by the positions of dip switches 1 to 6, with valid addresses lying between 1 and 32 inclusive.

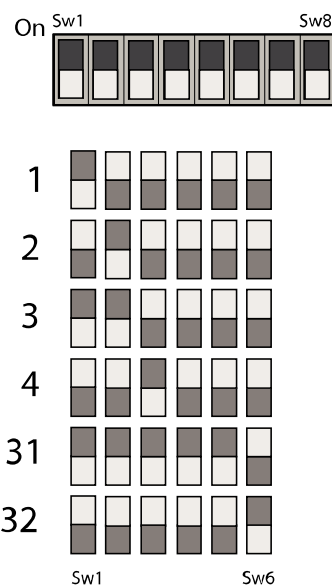

Dip switch 7 selects the operation of the local fault relay; when it is OFF the relay closes when any point is in use, when the switch is ON the relay opens when any fault occurs on the system.



Dip switch 8 is used to protect the exchange unit data. If this dip switch is ON, then the data can be configured normally. If this dip switch is OFF, then the data is protected. This setting determines the padlock setting in the configuration menus

VoCALL Master unit switch settings

The master handset has two jumper switches on the rear of the main circuit board which determine the hardware settings for the system.

In a LINE system the jumpers on all Master Handsets should be set to SLAVE.

In a RING system the jumpers on Master Handset 1 should be set to MASTER, all others if they exist should be set to SLAVE

Batteries

The VoCALL Exchanges require a single 12V 7AH sealed lead acid batteries to provide backup power in the event of mains failure as defined in BS5839pt9 for 24 hours standby and 3 Hours operation.

For 72hour standby and 1 hour operation a single 12V 17AH battery is required, the monitored charger in the VoCALL Exchange is capable of charging and monitoring these batteries however it must be located in a separate box

Powering up the system

Carefully check the network wiring then apply AC power to each exchange unit in turn- DO NOT commission on batteries as the power supply has a large reservoir capacitor which will rupture the battery fuse if the AC is not present when powering up the system. Once the system is powered, the battery leads can be attached to the battery.



Safety Information:

Sealed Lead acid batteries contain sulphuric acid which can cause burns if exposed to the skin, the low internal resistance of these batteries means large currents will flow if they are accidentally short circuited, causing burns and a risk of fire- exercise caution when handling batteries.

Power Up Procedure:

Always apply mains power before connecting batteries, do not commission VoCALL on batteries, as the high inrush current required by the power supply may rupture the battery fuse.

Always connect the Positive (Red +) terminal first.

Power Down Procedure

Disconnect the batteries before removing the mains power; always remove the negative (Black – terminal) first.

System Configuration

VoCALL master unit access

```
Current Thinking
VoCALL Master v4.5
-System Healthy-
10:24:01 07106109
```

The exchange units are configured via the master unit or via the VoCALL configuration software suite, however the master and network settings need to be configured before programming can commence. To log in to the master unit, press the `accept` button (middle square button below the display) to show the log in screen:

If the system is in fault, pressing the `Accept` button will silence the buzzer, and a silence buzzer message will be shown. Buzzer silenced means that it will give a single beep once every 15 seconds, instead of the continuous cyclic tone that sounds when a fault has occurred. Press the `Accept` button again to show the log in screen.

```
VoCALL Master v4.5
>Login
Back
```

The log in screen will prompt the user to enter a PIN. The default PIN is 0000. Use the navigation keys to choose the correct number, and then press `Accept` to move to the next number. Repeat until the PIN is entered. Alternatively use the keypad to enter the PIN.

```
Enter PIN to LOG IN
0***
```

A list of possible menu options is presented. `Log off` will be currently selected. Use the navigation keys to select the option required, and press the `Accept` button.

```
VoCALL Master v4.5
Config Exchange
>Log off
View Event Log
```

Log off

This option exits the configuration menu and returns the master unit back to standard operation.

Scroll through the root menu using the navigation keys until `Log off` is selected. Press `Accept` to exit.

Network settings

Before any exchange can be configured, the master unit network settings need to be checked. Scroll to the `Network settings` option (left button twice) and press `Accept`.

```
Network Settings
Back
>Network Config
Exchange Addresses
```

Pressing `Accept` again will show the `Network Config` menu, with the `Present` option currently selected. If this is `None`, the master unit will not communicate to any other unit, and will be effectively isolated. If `Line` or `Ring`, then the master unit will become part of the network (this is chosen based on the installed topology). Use the navigation keys to toggle between the 3 options, and press `Accept` to move onto `Node ID`.

```
Network Settings
Present>Line
Node ID:1
Mon Port:NO :NEXT
```

Each master must have its' own unique ID. These ID numbers range from 1 to 8. This node ID is used to uniquely identify the master unit. Use the navigation keys to select the node ID for this master unit, and press `Accept` to move to the `Next` option.

We now need to set which port is monitored on the handset and this depends on which one(s) are connected from `IN`, `OUT` or `Both`.

Most configuration menus will have the same options located in the bottom right of the LCD screen: `Next`, `Save`, and `Quit`. Pressing the `Accept` button selects the option chosen:

`Next`: moves cursor back to first option on screen.

`Save`: stores information and moves back to the previous menu screen.

`Quit`: discards all information on screen, and moves back to the previous menu screen.

We must now tell the system how many Exchanges should be present on the system:

```
Network Settings
Network Config
>Exchange Addresses
Master Addresses
```

Scroll to the `Exchange addresses` option and press `Accept`.

```
Exchange Addresses
1>Y 2:N 3:N 4:N
5:Y 6:N 7:N 8:N
9:Y 10:N 11:N :Next
```

Using the up and down keys to toggle Yes or No and the accept key to move to the next value, set the valid addresses for exchanges present on the system; when you reach next, pressing accept will take you to page 2, save will store and quit will leave as usual.

Finally we must tell the system how many master addresses are Used

```
Network Settings
Exchange Addresses
>Master Addresses
Back
```

Scroll to the Master addresses option and press Accept.

```
Master Addresses
1=Y 2>N 3:N 4:N
5:Y 6:N 7:N 8:N
      :Next
```

Using the up and down keys to toggle Yes or No and the accept key to move to the next value, set the valid addresses for exchanges present on the system; when you reach Next, pressing accept will take you to back to the start, Save will store and Quit will leave as usual. The = sign appears at the address you set in the network configuration menu as this is your address.

Exchange unit configuration

Scroll to the Config exchange menu and press Accept. This menu consists of a list of all 32 possible exchange units, plus a Back option. The network address of each exchange is shown, along with a symbol:

```
Select Exchange
⊘Exchange 32
>Back
🔒Exchange 1
```

Open padlock: this exchange exists and memory is unprotected.

Closed padlock: this exchange exists and memory is protected.

Line through circle: this exchange does not exist and will not be used.

Select the exchange unit to be configured and press Accept. This menu consists of a list of all 8 extensions, a Back option, and a Network faults option.

```
Exchange 1 🔒
Back
>Line 1
Line 2
```

Each existing exchange on the network must be configured before use. For each exchange, configure the extension details, where extension 1 refers to the handset(s) attached to line 1, etc. Each extension has a name and a number of handsets per line. All lines to be used must be configured.

The `Back` option on the `Select extension` menu will go back to the `Select exchange` menu, whilst selecting `Back` on the `Select exchange` menu will go back to the root menu.

Set extension name and handset present per line

Select the extension to be configured and press `Accept`. This will show the details for that extension.

```

Name exc9 1   Line 1
>Extension 1   <
Present Yes   (Yes)
               =Next
  
```

Use the navigation keys to change the first character of the extension name, and press `Accept` to move to the next character. Repeat for all characters. Press `Accept` on the last character to move the cursor to the `Present` option.

Use the navigation keys to say if an outstation should be present on this extension (the text in brackets shows if the exchange has detected an extension on this line). Press `Accept` to move the cursor onto `Next`.

Use navigation keys to select `Next`, `Save`, or `Quit`, and press `Accept` to select option. `Save` also updates the information stored in the exchange unit.

Note: if the memory is protected (Locked padlock symbol shown for the exchange), then you will only be able to view this information. The cursor will be on the `Quit` option, and this will be the only option that can be selected. Pressing `Quit` will move back to the `Select Extension` menu.

Set network fault monitoring for exchange unit

In `Select extension` menu, choose the `Network faults` option. Each exchange unit can have up to 2 data cables attaching it to the network: network in and network out. If desired, each cable can be monitored independently.

```

Exchange 1 
Line 8
>Network Faults
Exchange Details
  
```

The `Network faults` screen shows 2 options: `net in` and `net out`. Use the navigation keys to select if this data cable is to be monitored, and press `Accept` to move to the next option.

```

Exchange 1 Network
Net In Yes (Yes)
>Net Out No (No )
               =Next
  
```

Next to each option, the current status of that cable is shown. If there are no faults, Yes is shown in brackets. No is displayed if there is a fault, or the cable is not present. Use navigation keys to select Next, Save, or Quit, and press the Accept button to select option.

View Exchange Details

In Select extension menu, choose the Exchange Details option. Each exchange unit will show it's current software revision, and a line of text which can be set from the configuration software.

```
Exchange details
Version 4.2
Exchange 1
                                >Quit
```

Edit site name

If the site name is to be changed, scroll through the menu options until Edit site name is selected, then press the Accept button.

```
Edit site name
>Current Thinking <
                                : Next
```

The current site name will be displayed on screen, with the cursor on the first character. Use the navigation keys to scroll to the correct character then press Accept. Repeat until the new site name has been entered.

Pressing Accept on the last character will move the cursor to the Next option. Use the navigation keys to select Next, Save, or Quit as desired, then press Accept. Both Save and Quit will go back to the root menu.

Edit Master name

On the system each master can be given a unique name, if the master name is to be changed, scroll through the menu options until Edit master name is selected, then press the Accept button.

```
Edit master name
>VoCALL Master 4.5<
                                : Next
```

The current master name will be displayed on screen, with the cursor on the first character. Use the navigation keys to scroll to the correct character then press Accept. Repeat until the new site name has been entered.

Pressing Accept on the last character will move the cursor to the Next option. Use the navigation keys to select Next, Save, or Quit as desired, then press Accept. Both Save and Quit will go back to the root menu.

Set date and time

Scroll through the root menu using the navigation keys until `Set date & time` is selected. Press `Accept` to show the `Set date & time` menu.

```
Set date & time
Date >01106109
Time 14:15:06
:Next
```

This menu shows the current date and time in the following format:

```
Day|Month|Year
Hour:Minute:Second
```

The cursor will be on the first option: `Day`. Use the navigation keys to select the correct day then press `Accept` to move to the `Month` option. Repeat until the current date and time are set and the `Next` option is selected.

Use the navigation keys to select `Next`, `Save`, or `Quit` as desired, then press `Accept`. Both `Save` and `Quit` will go back to the root menu.

Set service date

The service date is used as a reminder when the next service is due. When this date is reached, it will trigger a service fault which will remain until the service date is updated.

Scroll through the root menu using the navigation keys until `Set service date` is selected. Press `Accept` to show the `Set service date` menu.

```
Set service date
Date >01106110
:Next
```

This menu shows the currently selected service date in the following format:

```
Day|Month|Year
```

The cursor will be on the first option: `Day`. Use the navigation keys to select the correct day then press `Accept` to move to the `Month` option. Repeat until the desired next service date is set and the `Next` option is selected.

Use the navigation keys to select `Next`, `Save`, or `Quit` as desired, then press `Accept`. Both `Save` and `Quit` will go back to the root menu.

Change PIN

The default PIN to access the configuration menus is 0000, but this can be changed.

Scroll through the root menu using the navigation keys until `Change Pin` is selected. Press `Accept` to show the `Change Pin` menu.

There are 2 lines: `New PIN` and `Repeat PIN`. The cursor will be on the first digit of the `New PIN`. Use the navigation keys to change the digit, and press `Accept` to move to the next digit. Repeat until all digits have been entered for both the `New PIN` and the `Repeat PIN`, and the `Next` option is selected.

```
Change PIN
New PIN    0****
Repeat PIN ****
           : Next
```

New PIN: PIN number that will be used to access the configuration menus.

Repeat PIN: new PIN repeated. If this differs from the new PIN, then the new PIN number will not be accepted, and a warning message will be displayed on screen.

Use the navigation keys to select `Next`, `Save`, or `Quit` as desired, then press `Accept`. Both `Save` and `Quit` will go back to the root menu.

Event log settings

The event log is a record of the last 99 events: the type of event and the date and time the event occurred. The following are classed as events: faults occurring, faults cleared, configuration change, log in & log off actions, system reboot requested (reboots master unit), system initialised (on power up). This menu will clear the event log, erasing the record of all events recorded to date.

```
Event Log settings
Clear Log >No
           : Next
```

Scroll through the root menu using the navigation keys until `Event log settings` is selected. Press `Accept` to show the `Event log settings` menu.

The cursor will be on the first option, `Clear log`. Use navigation keys to select either yes or no then press `Accept` to move to the `Next` option.

Unlike other menus, the `Next` option toggles between `Next`, `Exec`, and `Quit`. Use the navigation keys to select the desired option, and then press `Accept`.

Next: moves cursor back to `Clear log` option.

Exec: executes command to clear log if **Clear log** option is set to yes. Moves back to root menu.

Quit: moves back to root menu.

View event log

This menu is an information only menu. It displays the last 99 events that have occurred, recording the type of event and the date and time the event occurred. The following are classed as events: faults occurring, faults cleared, configuration change, log in & log off actions, system reboot requested (reboots master unit), system initialised (on power up).

```
Event 1 of 99
Logged On
02106109 10:30:54
```

Scroll through the root menu using the navigation keys until **View event log** is selected. Press **Accept** to enter the **View event log** menu.

Use the navigation keys to scroll through the events.

If a fault has occurred, and the buzzer has not yet been silenced, pressing **Accept** will silence the buzzer.

System reboot

This menu option will reboot the master unit. The master unit will momentarily power down, then power up again. When it powers up, the master unit will be reinitialised with the currently stored settings. This is only to be used when absolutely necessary as all exchange unit data held in RAM is lost, and will have to be rebuilt on power up. The network communication flow will stutter as this unit drops from the network on power down, and its place in the data flow will have to be re-established on power up.

```
System Reboot
Reboot >No
: Next
```

To reboot the master unit, scroll through the root menu until **System reboot** is selected. This will show the **System reboot** menu.

There is only one option that defaults to no. A warning is displayed to advise the user on the consequences of selecting **Yes**. Use the navigation keys to toggle between **No** and **Yes**. Press **Accept** to move to the **Next** option.

Use the navigation keys to toggle between **Next**, **Exec**, and **Quit**.

Next: moves back to the **Yes/No** option

Exec: if **Yes** is selected, the master unit is rebooted. If **No** is selected, the root menu is shown.

Quit: moves back to the root menu.

System LED Test

This menu option will test the panel LEDs to prove operation.

```
LED Test
                                     >Quit
```

Set Relays

This menu option does not work with the current VCM and VCWM Hardware and is for future updates.

System Operation

All conversations on the VoCALL system are under the command of the control handset, if multiple control handsets exist, the first operated one takes command of the system.

Pt9 envisages the majority of calls to be made by lifting the handset of an outstation (type A) or pressing the call button (type B).

Receiving a call.

When a handset is lifted or the call button is pressed on the type B units, the phone on the control point(s) will ring and the name of the calling extension will appear on the LCD display (all exchange lines can be given a unique 16 character name to identify themselves such as "Floor 1 Riser E").

The operator can then lift the handset and connect to the calling extension by pressing the # key. If more than one line is calling, all calling lines show in the display, and may be scrolled through with the navigate buttons, connected using the # key, or if already connected placed on hold using the # key a second time.

If the control wishes to ring an outstation they may do this in one of two ways, either by entering the number of the outstation using the keypad, or by scrolling through the names in the directory function and pressing # over the line they want. To call all extensions select ALL from the directory and press # or dial 0#.

Making a Call:

Lift the handset on the control phone, then either:

Dial the number of the line you require and press # to call, the line will connect automatically when the remote handset is lifted or the call button is pressed.

Press the * key to scroll the display to the directory page. Once in the directory use the up and down keys navigation to select the extension name you wish to call, and press # to call. The line will connect when answered.

Ending or Holding a Call

Both call types can be ended by pressing the # key on the exchange line you no longer wish to call (if the bell symbol is shown).

Pressing # while a remote outstation is speaking or is off hook will place the line on HOLD (the symbol of an off hook phone is shown), you can talk to this line again by scrolling to it and pressing # again

Making a Call to another master (multi-master systems only):

Lift the handset on the control phone, then either:

Dial the number of the master you require (001 for master 1, 008 for master 8) and press # to call, the line will connect automatically when the remote handset is lifted or the call button is pressed.

Press the * key to scroll the display to the directory page. Once in the directory use the up and down keys navigation to select the master name you wish to call, and press # to call. The line will connect when answered.

Maintenance.

It is a requirement of BS5839pt9 that a maintenance agreement be in place for the EVCS, the maintenance schedule should be as follows.

Weekly: Lift a different handset on the system each week and make a call to the control, repeat each week until all points are tested, record results in the site log.

Monthly: Test one handset on each exchange by lifting the handset, followed by the master calling the line, record results in the site log.

Quarterly: Engineer Call to check system operation.

Yearly: Engineer Call to check system operation and check Battery Health.

5 Yearly: Engineer Call to check system operation and replace the batteries.

The VoCALL EVCS is designed and manufactured in the UK by

Current Thinking Ltd,

Unit 91 Silver Briar

Enterprise Park East,

Sunderland,

SR5 2TQ.

www.current-thinking.com

info@current-thinking.com